



# Analysts' Conference on FY2020 figures

Dr. Stefan Wolf, CEO | Thomas Jessulat, CFO  
March 30, 2021



FY 2020

## Headlines

- **Top line decrease** of -14.3% to EUR 1,480m, **organically down by -11.7%**, while **global LV production declined by 16 %**
- Despite pandemic impact, **EBITDA on previous year's level** at EUR 181m
- **EBIT positive** at EUR 27.7m, EBIT margin at 1.9%; results influenced by various factors
- **Operating free cash flow in the triple-digit million euro-range** for the second year in a row at EUR 165m
- **Net debt significantly reduced** to EUR 459m, net debt/EBITDA now at **2.5**
- **Suspension of dividend** for the covid-19-year 2020
- **Annual general meeting** on FY 2020 on May 18, 2021 **in virtual form**

FY 2020

## The pandemic at ElringKlinger: prevention and cohesion

- ElringKlinger has already taken rigorous **preventive measures at a very early stage**, e.g.:
  - Reporting mechanism on local and on Group level
  - Travel and visit ban
  - Internal coronavirus rules of conduct including cleaning routine
  - Canteen shifts per building
  - Body temperature measurement at Chinese locations
  - Body scanners in US locations
- Strict measures to stay **in place for the foreseeable future** to contain pandemic and guarantee production output
- **Strong cohesion** of employees in different locations



FY 2020

## Two major steps in strategic development of fuel cell business



1



Long-term **partnership with Airbus** to develop a hydrogen-based fuel cell stack for airplanes

Shared ambition:  
**Reaching emission-free aviation**

2

**EKPO** FUEL CELL TECHNOLOGIES

Strategic **alliance with Plastic Omnium** by a joint company on fuel cell stacks and components

Shared vision:  
**Unlocking emission-free hydrogen mobility**

# Markets and strategy

H<sub>2</sub>

# Dynamic rebound in China, longer recovery in Europe and USA

Monthly passenger car sales 2020 vs. 2019 – in %

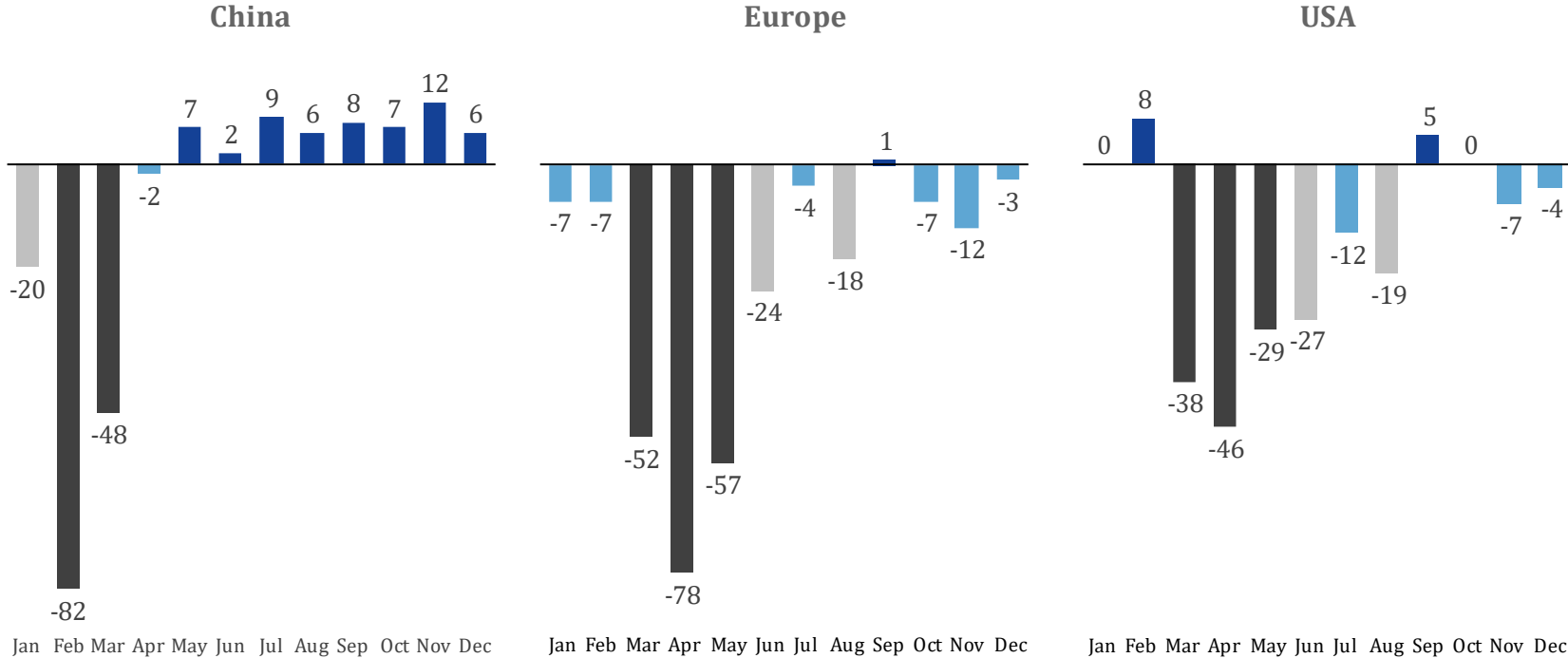

Source: BCG (based on Marklines, CAAM, ACEA, Wards Automotive), St. Louis FED, ElringKlinger Research

# Autos overall a growing market – irrespective of pandemic

Global light vehicle production per drivetrain – in million units

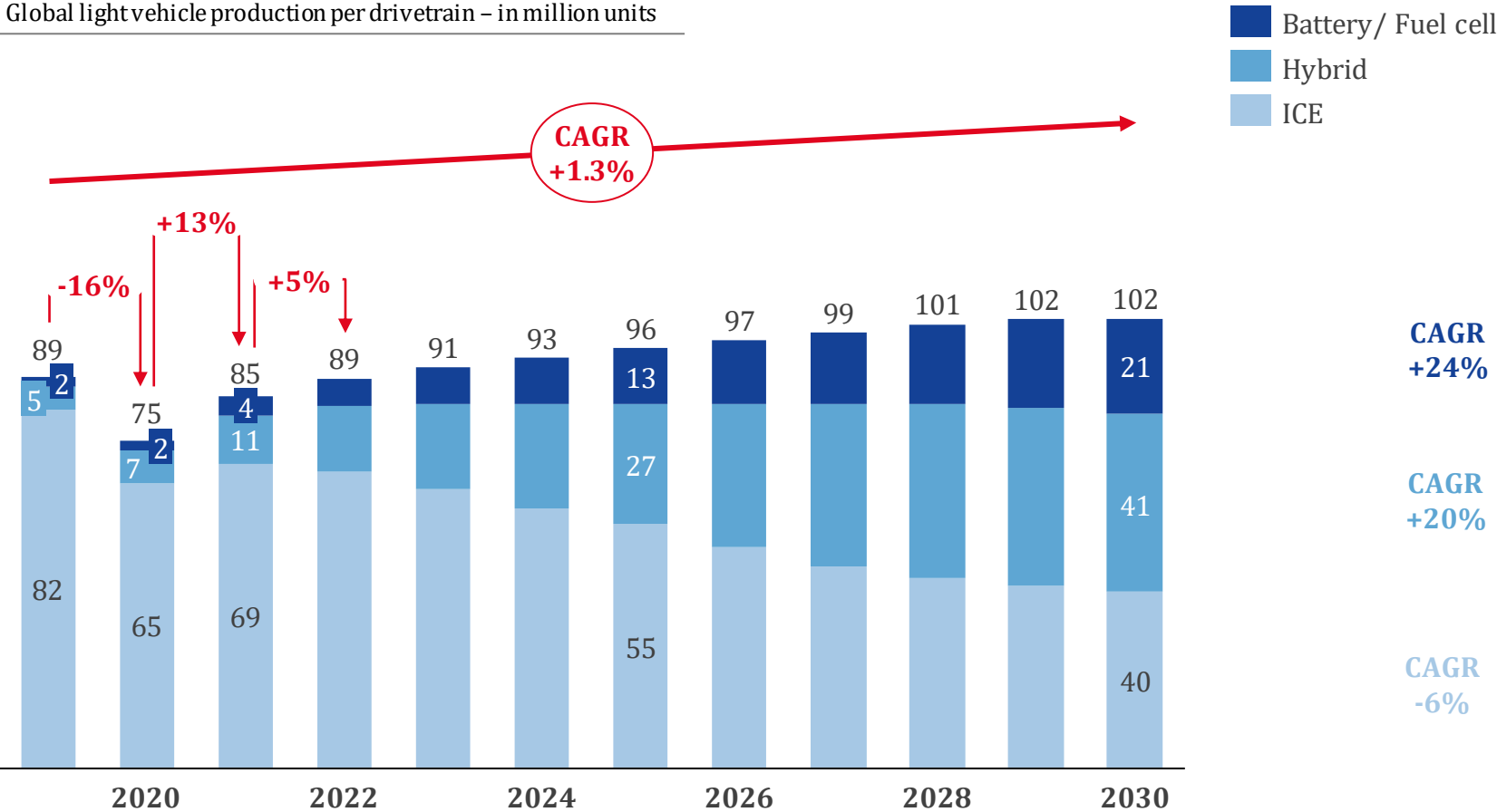

Source: IHS (03/2021), ElringKlinger Research

# Strong potential for EV cars particularly in China and Europe

LV production by region – in million units

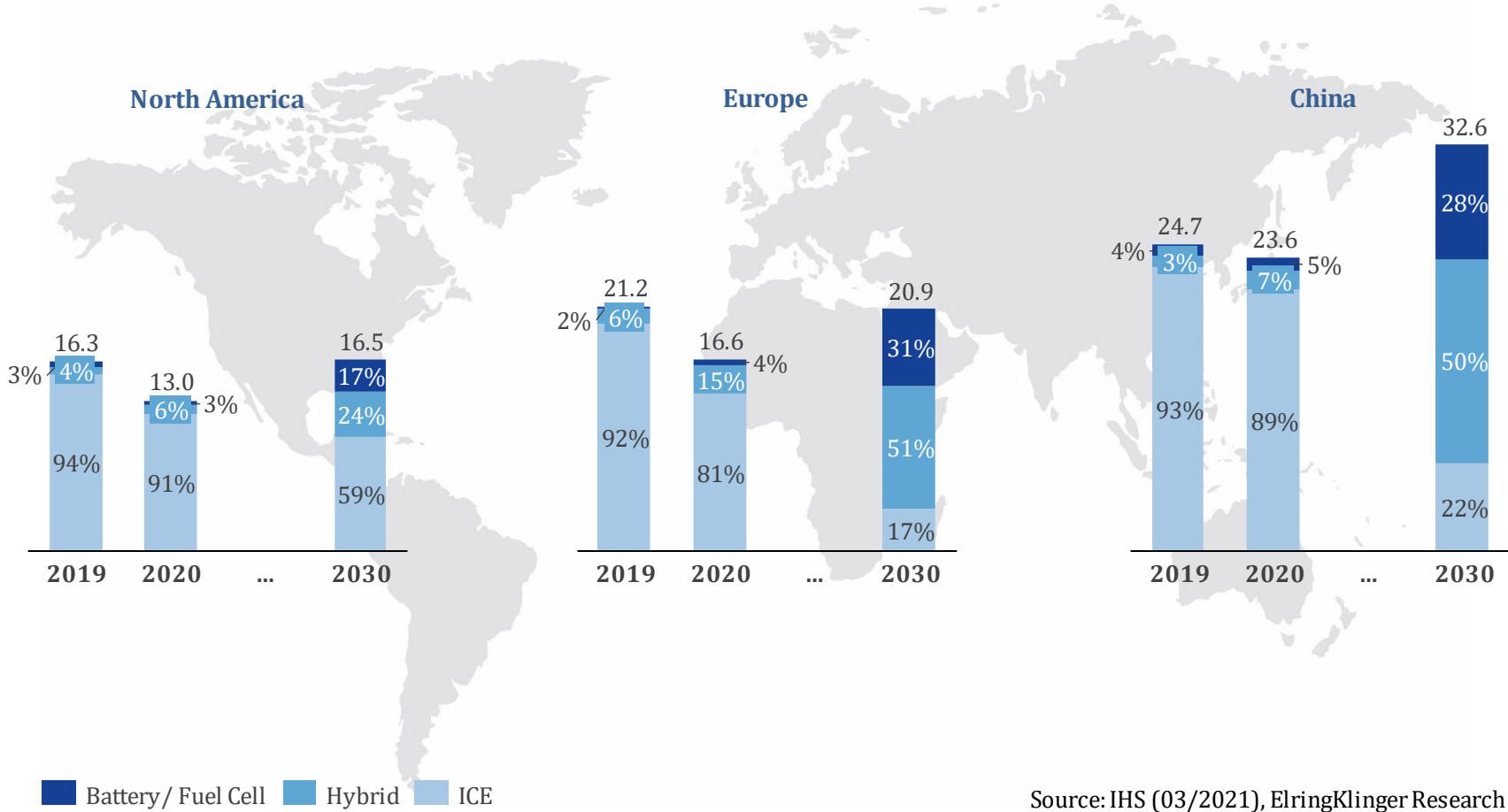

Source: IHS (03/2021), ElringKlinger Research



# Roadmap for continuing transformation

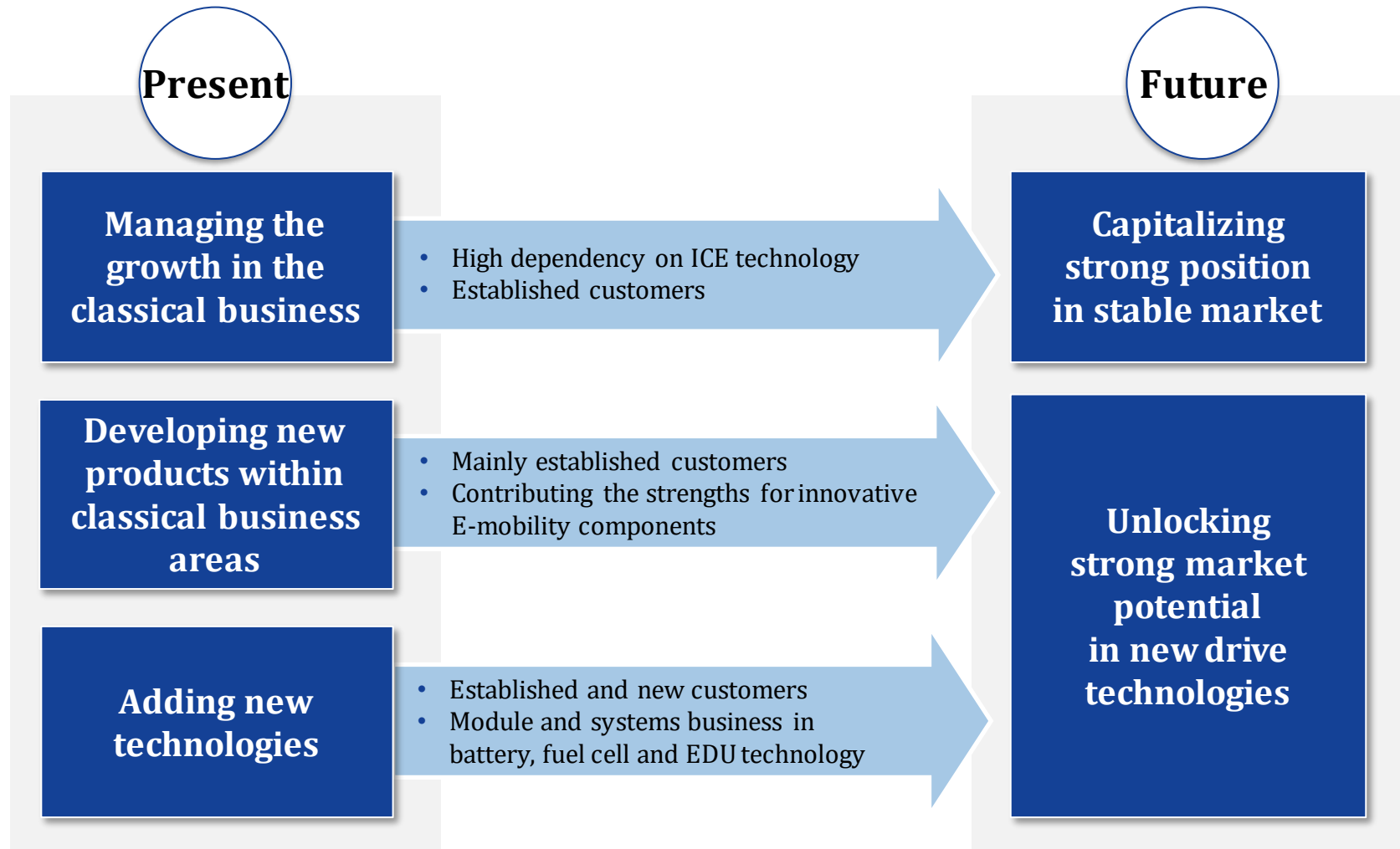

# Level of car production including an ICE more or less stable

**Future**

**Capitalizing strong position in stable market**

**Unlocking strong market potential in new drive technologies**

Global light vehicle production per drivetrain – in million units

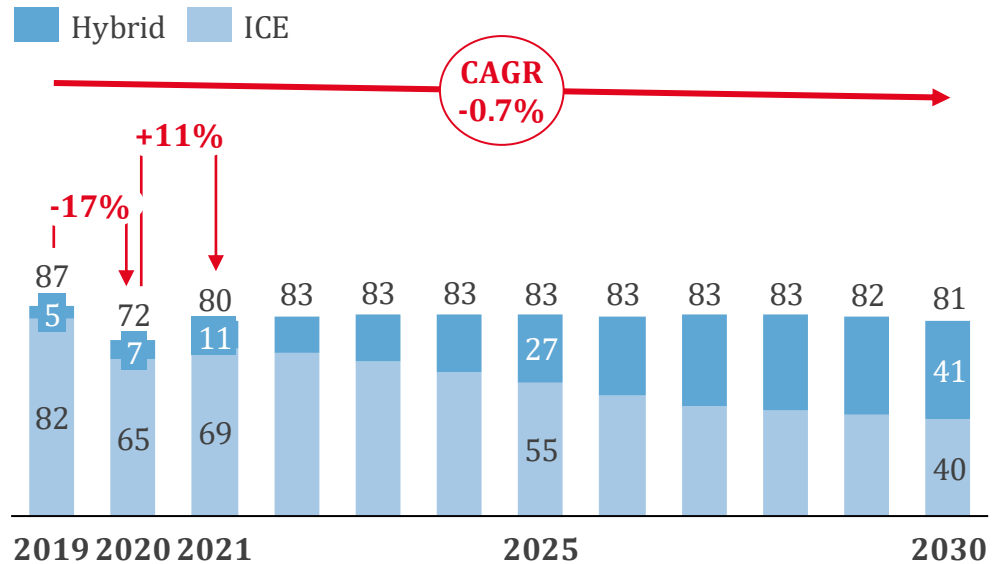

Source: IHS (03/2021), ElringKlinger Research

# New technologies will drive growth of global auto production

**Future**

Capitalizing strong position in stable market

Unlocking strong market potential in new drive technologies

Global light vehicle production per drivetrain – in million units

■ Battery/ Fuel cell ■ Hybrid

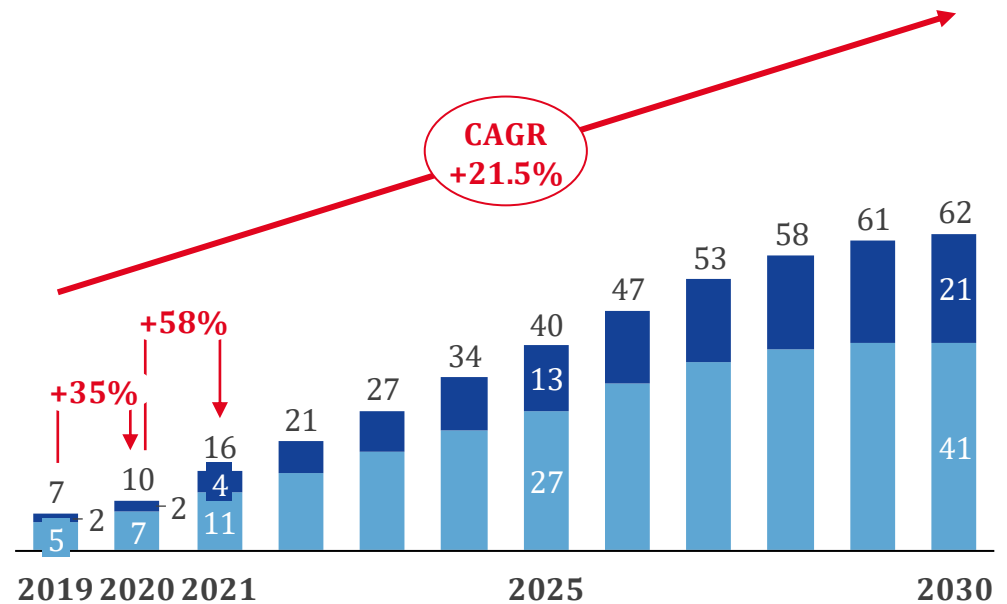

Source: IHS (03/2021), ElringKlinger Research

# Innovative solutions based on proven know-how in classical business

**Fuel cell technology**

A vertical fuel cell stack with multiple grey rectangular cells and black top and bottom covers.

**Battery technology**

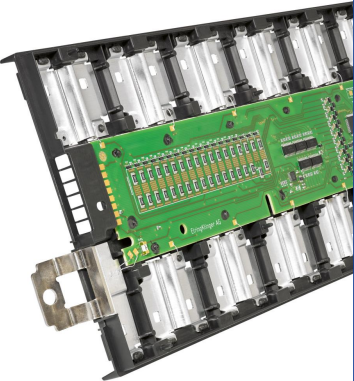
A battery pack showing a green printed circuit board (PCB) with electronic components, mounted on a black frame with several cylindrical cells.

**Electric drive units**

A cylindrical electric drive unit with a silver metal housing and various ports and connectors.

**Structural lightweighting**

A complex, lightweight structural component, possibly a suspension part, made of a light-colored material.

**Classical business**

A collection of six classical automotive components: a piston, a cylinder head gasket, a timing belt, a timing chain, a valve train assembly, and a timing cover.

Key strategic area: Fuel cell technology

# Ramp-up of hydrogen applications over the upcoming decade

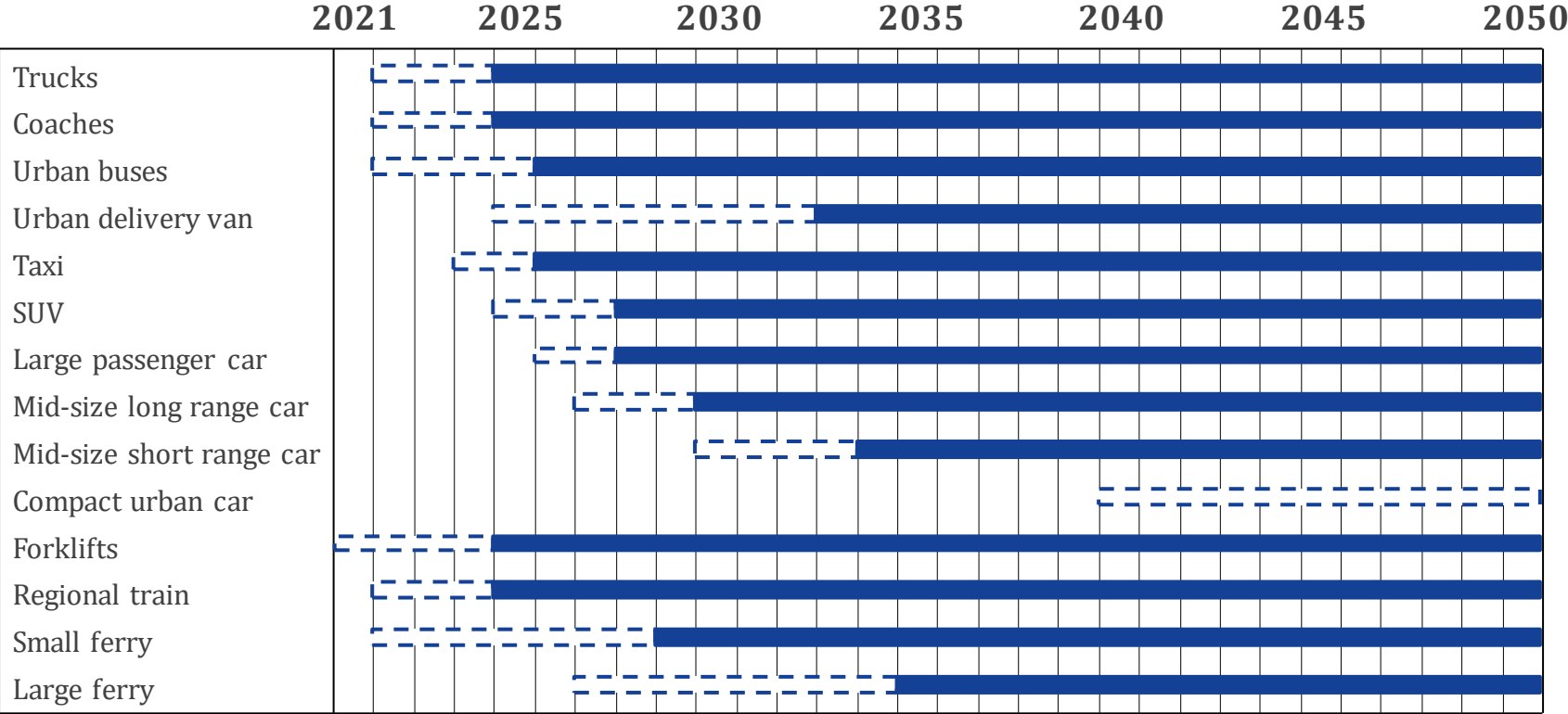

--- Hydrogen competitive in optimal conditions and regions    ■ Hydrogen competitive in average conditions and regions

Source: Hydrogen Council (2020), ElringKlinger Research

Key strategic area: Fuel cell technology

## Offering stacks and components via EKPO Fuel Cell Technologies

- Leading technology with **best-in-class power density**
- After the closing of the **strategic partnership with Plastic Omnium** on March 1<sup>st</sup>, 2021, new joint company **EKPO Fuel Cell Technologies** started its business activities
- **EKPO Fuel Cell Technologies with strong commitment**
  - Sales volume of EUR 700 million to EUR 1 billion by 2030
  - Aiming at market share of 10 to 15%
  - Focusing on trucks and buses in the first step, extending business to passenger cars with increasing numbers of production (economies of scale)
- Initial **production capacity of up to 10,000 stacks** per year, already according to automotive standards



Key strategic area: Battery technology

## ElringKlinger awarded new large-scale battery parts order

- Offering **systems and modules as well as components**
- **First series production started in 2012**
- **New location** in Neuffen, close to Dettingen/Erms, opened in January 2021
- **New large-scale contract** for cell contacting systems received
  - Over a term of 9 years
  - Total volume in the mid-triple-digit million-euro range
  - Customer: global battery manufacturer with a factory in Germany
  - End customer: German premium OEM

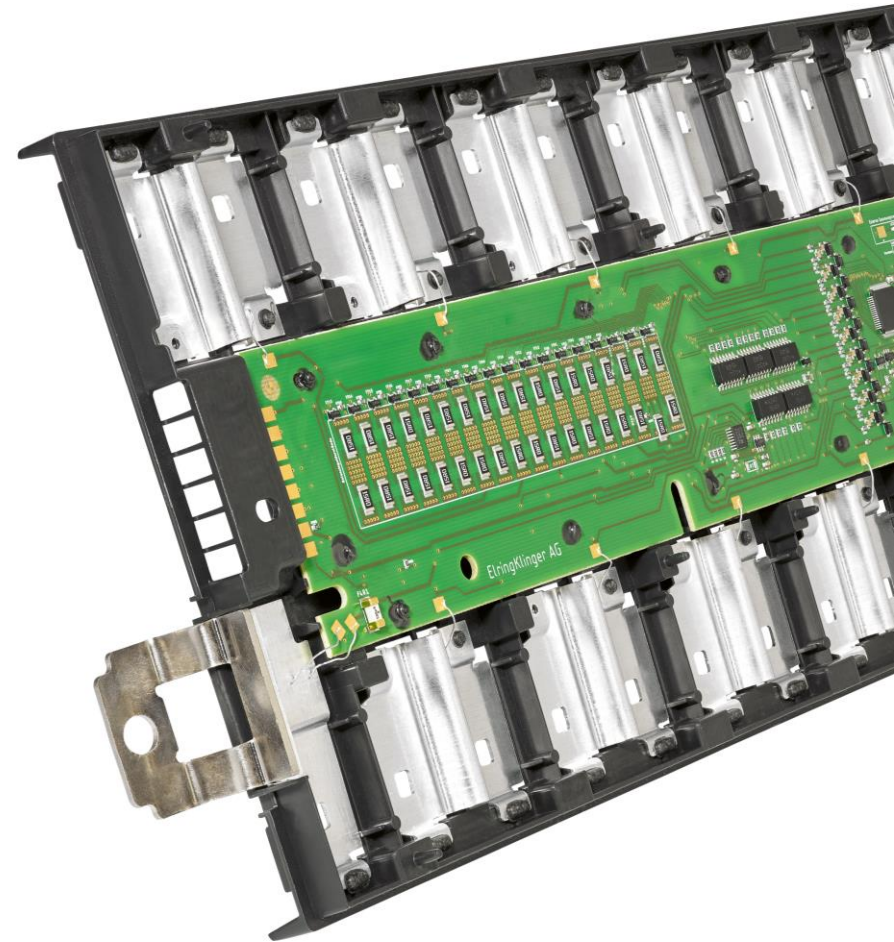

Key strategic area: Electric drive units

## Drivetrain business unit in production ramp-up phase

- Based on **strategic cooperation with hofer powertrain** since 2017
  - Minority stake in parent company hofer AG
  - **Majority stake in producing entities** (“hofer powertrain products”)
- **Targeting high-end sports and luxury car segment**
- **New plant** in the UK, SOP in H1 2021, future sales contribution in double-digit million-euro range

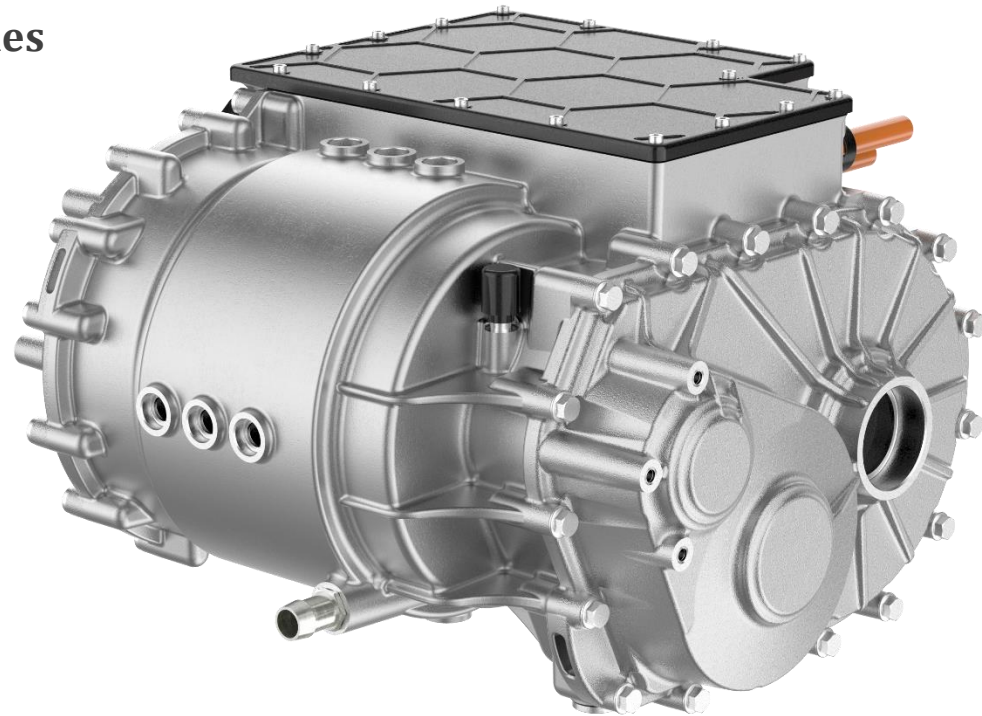



Key strategic area: Structural lightweighting

## Structural lightweighting – independent of drive technology

- Providing **sophisticated solutions for chassis** of a car, combining maximum functionality with minimum weight
- **High-end production technology** brings together high-pressure metal forming and plastic injection molding in just one production step, based on **unique tooling solutions**
- First series order by German premium OEM in 2014, meanwhile **further orders for vehicles of the next generation** received
- Latest development: **Underbody shield for protecting the battery**
  - Superior to metal solutions
  - Strong market potential

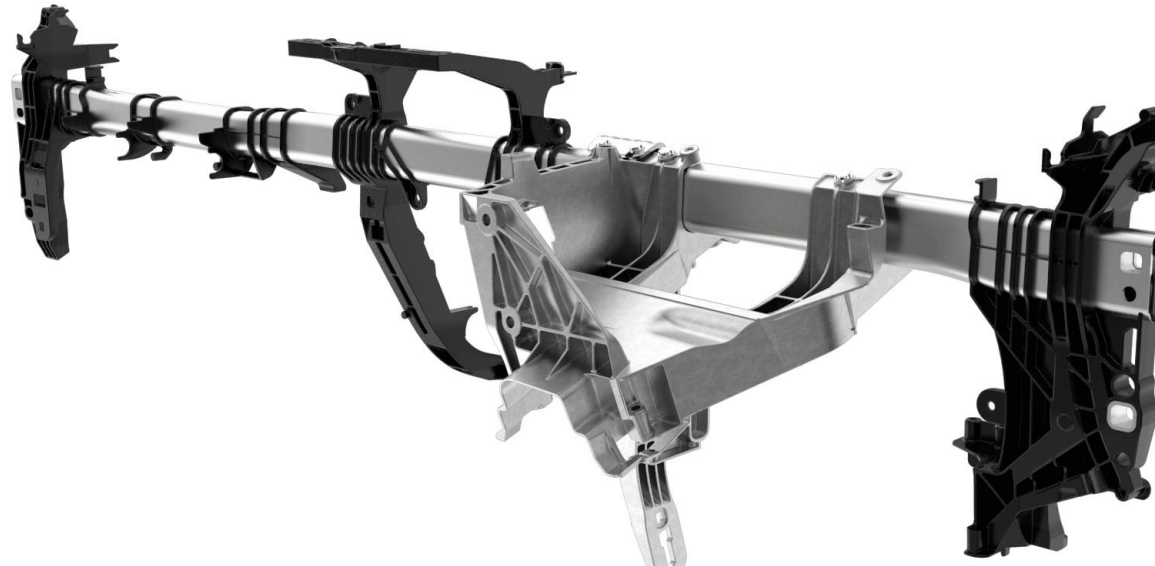

# Transformation and innovative product range drive content per car

Content per car – in EUR

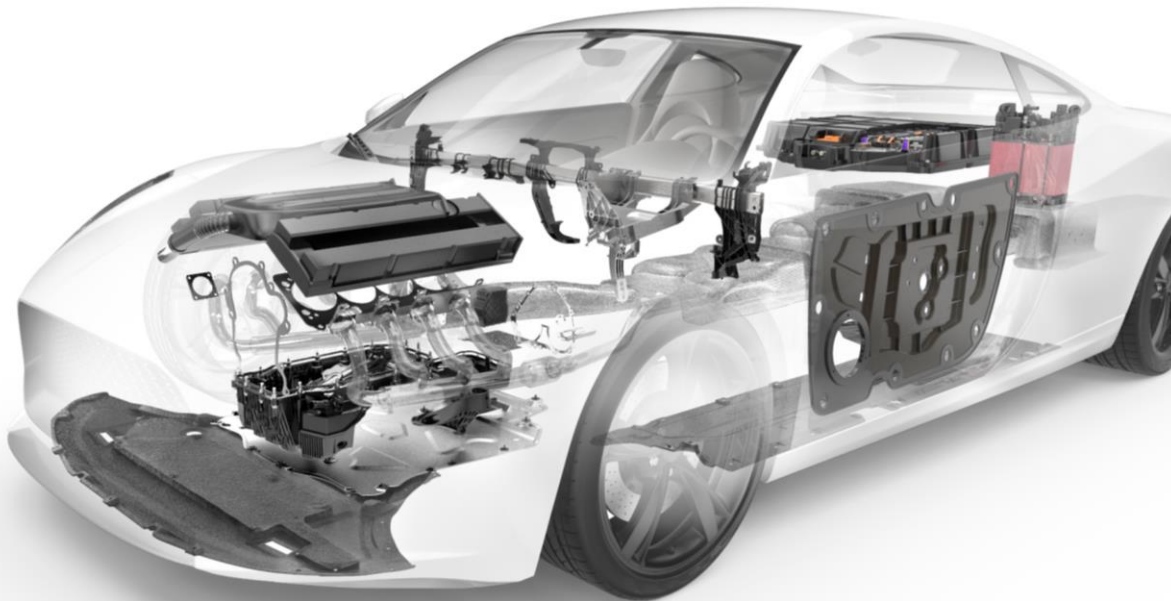

ICE	NON-ICE
Cylinder-head gasket <b>3 - 7</b>	Cell contacting systems <b>100 - 240</b>
Cylinder-head gasket <b>3 - 7</b>	Bipolar plates* <b>350 - 500</b>
Cam cover <b>15 - 20</b>	Media module <b>20 - 40</b>
Exhaust gas underbody shield <b>20 - 35</b>	Underbody battery protection shield <b>100 - 150</b>
[No similar product] <b>0</b>	Transmission disc carrier system <b>60 - 90</b>
[No similar product] <b>0</b>	Electric drive unit <b>1,000 - 3,000</b>
[No similar product] <b>0</b>	Battery system <b>2,000 - 10,000</b>
[No similar product] <b>0</b>	Fuel cell stack* <b>2,000 - 10,000</b>

\* Based on estimates for serial production in the second half of the decade

# Strong order pipeline for new technologies

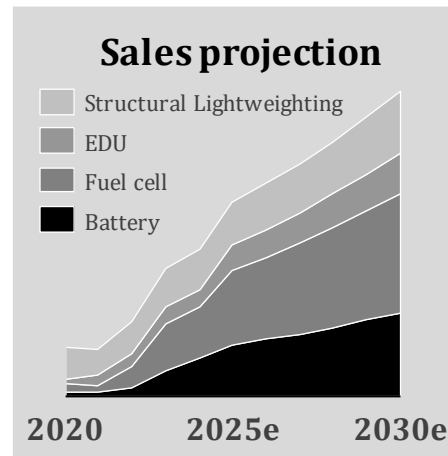
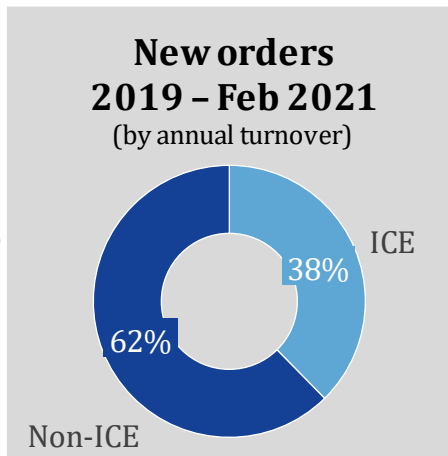
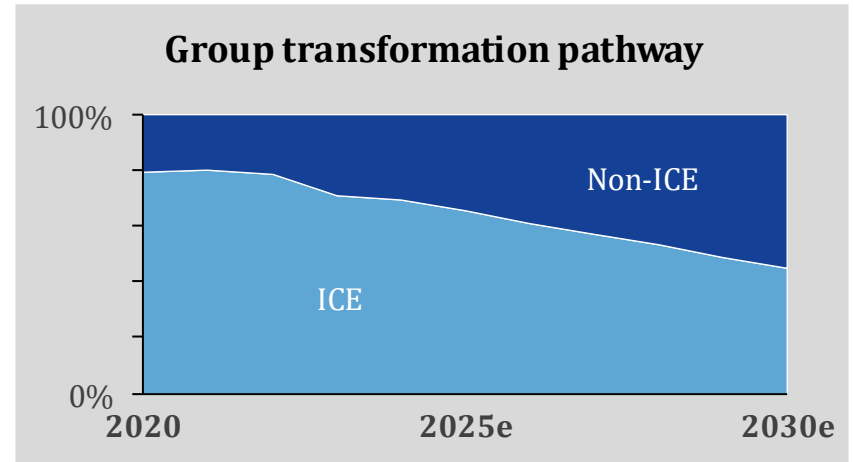
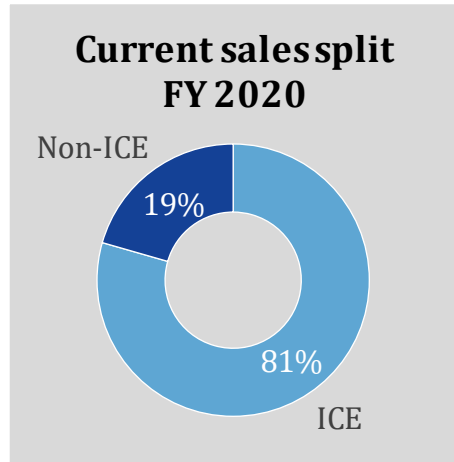

Non-ICE also includes non-automotive business as well as components that are independent of drivetrain technology. ICE also includes Aftermarket business. Data after 2025 based on growth assumptions.

# Financials

H<sub>2</sub>

A glowing, textured sphere with a bright core, surrounded by a blue, fibrous, web-like structure, set against a dark blue background. The sphere has a reddish-orange outer shell and a bright white and blue core. The surrounding structure is a complex, interconnected network of blue lines, resembling a molecular or cellular structure.

# Currency effects influencing orders and sales

Order intake – in EUR million

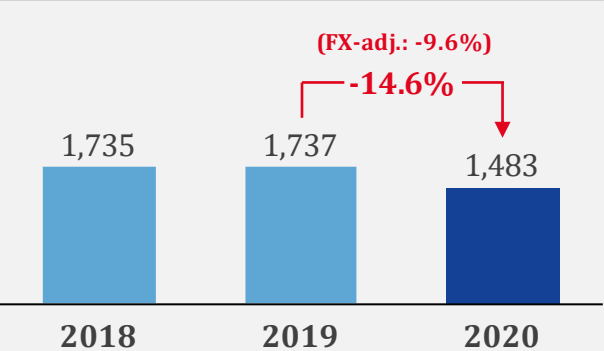

Order backlog – in EUR million

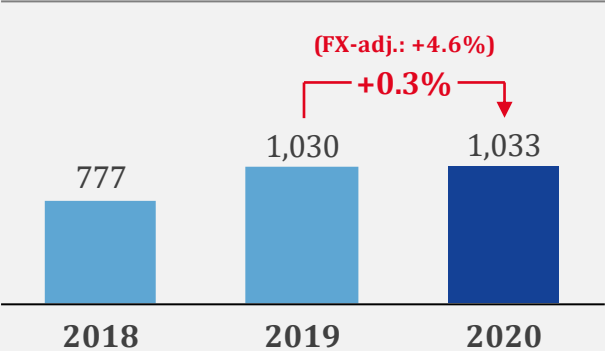

Sales – in EUR million

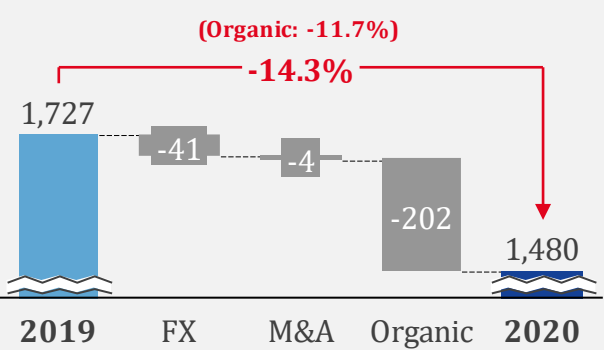

Global LV production – in million units

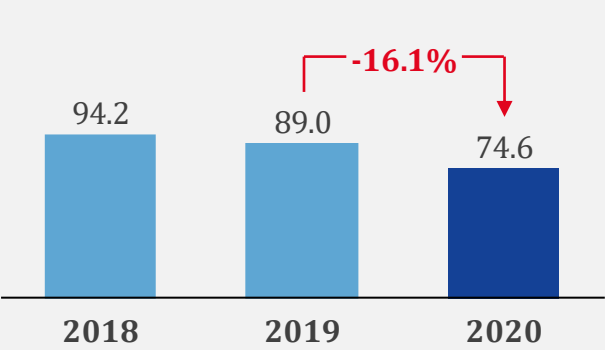

Source: IHS (03/2021)



- Recovery of sales and orders particularly in the second half of FY 2020
- Major currencies affecting sales: Mexican peso, Brazilian real, Turkish lira, US dollar

FY 2020: Sales

# Aftermarket and E-Mobility with increasing shares of sales

Sales by segment – in EUR million  
Share of total sales – in %

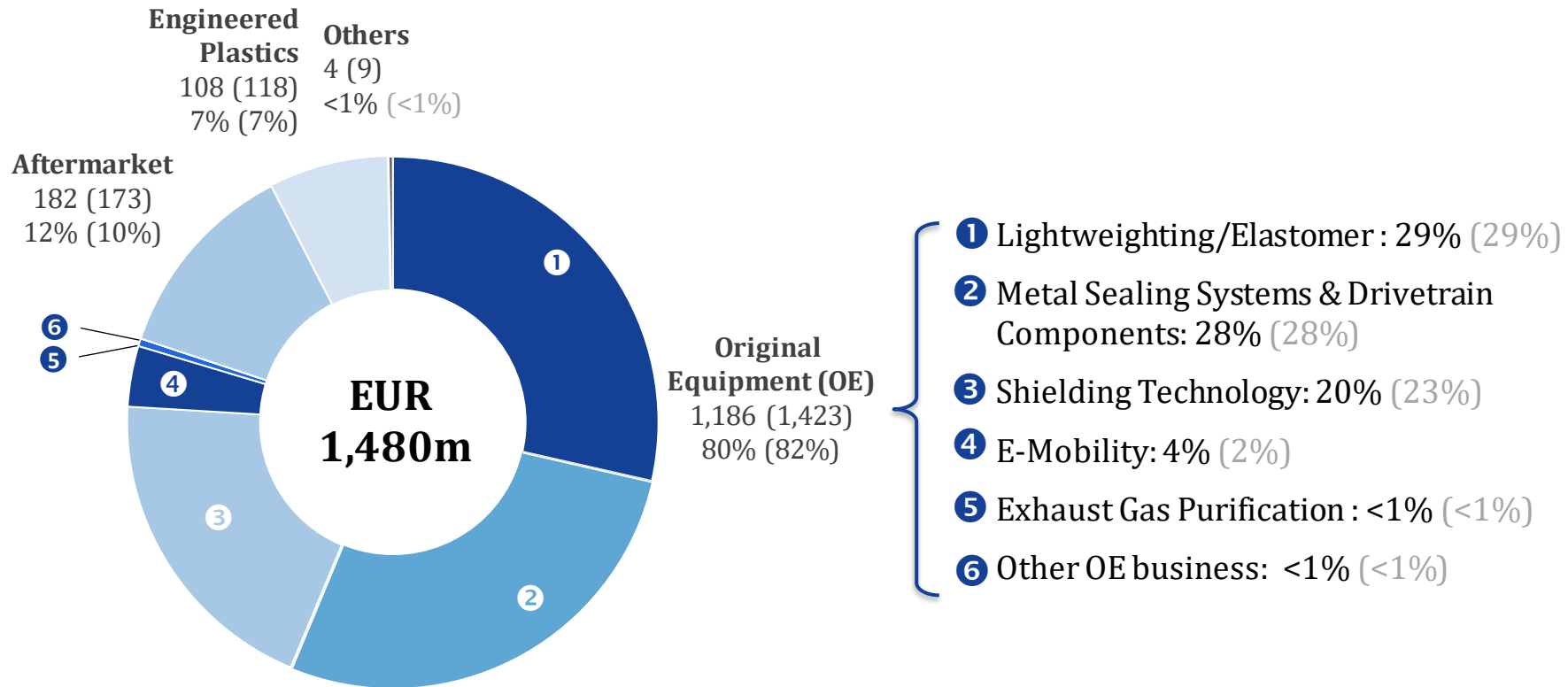

Previous year's figures in brackets

## Sales by region

# Impacted by pandemic, but more resilient than overall market

Growth LV production vs. sales ElringKlinger (FX adjusted) – in %  
Sales by region – in EUR million resp. %

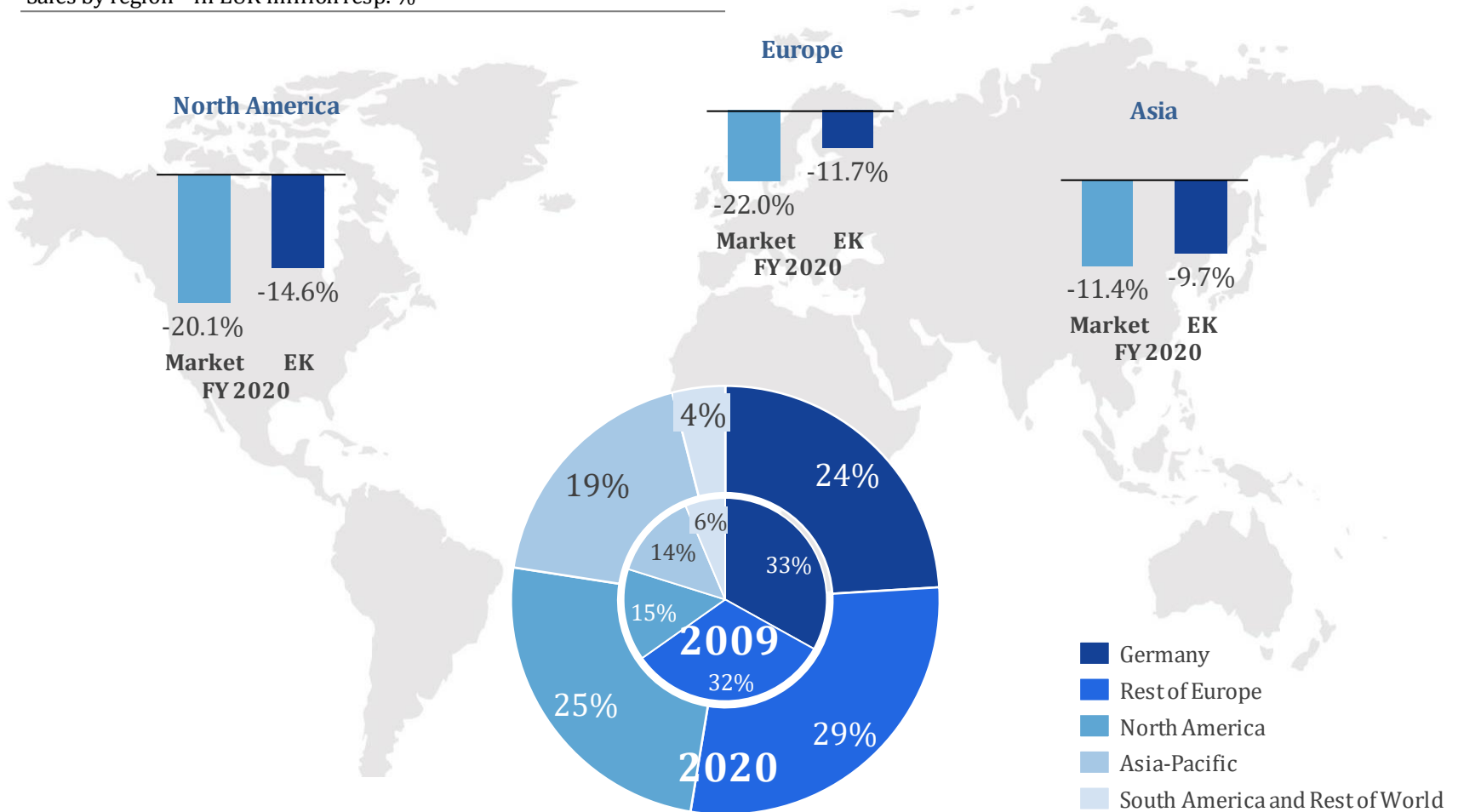

Sales by customer

# Diversified customer base for wide range of products

Sales by customer group – in % of total sales

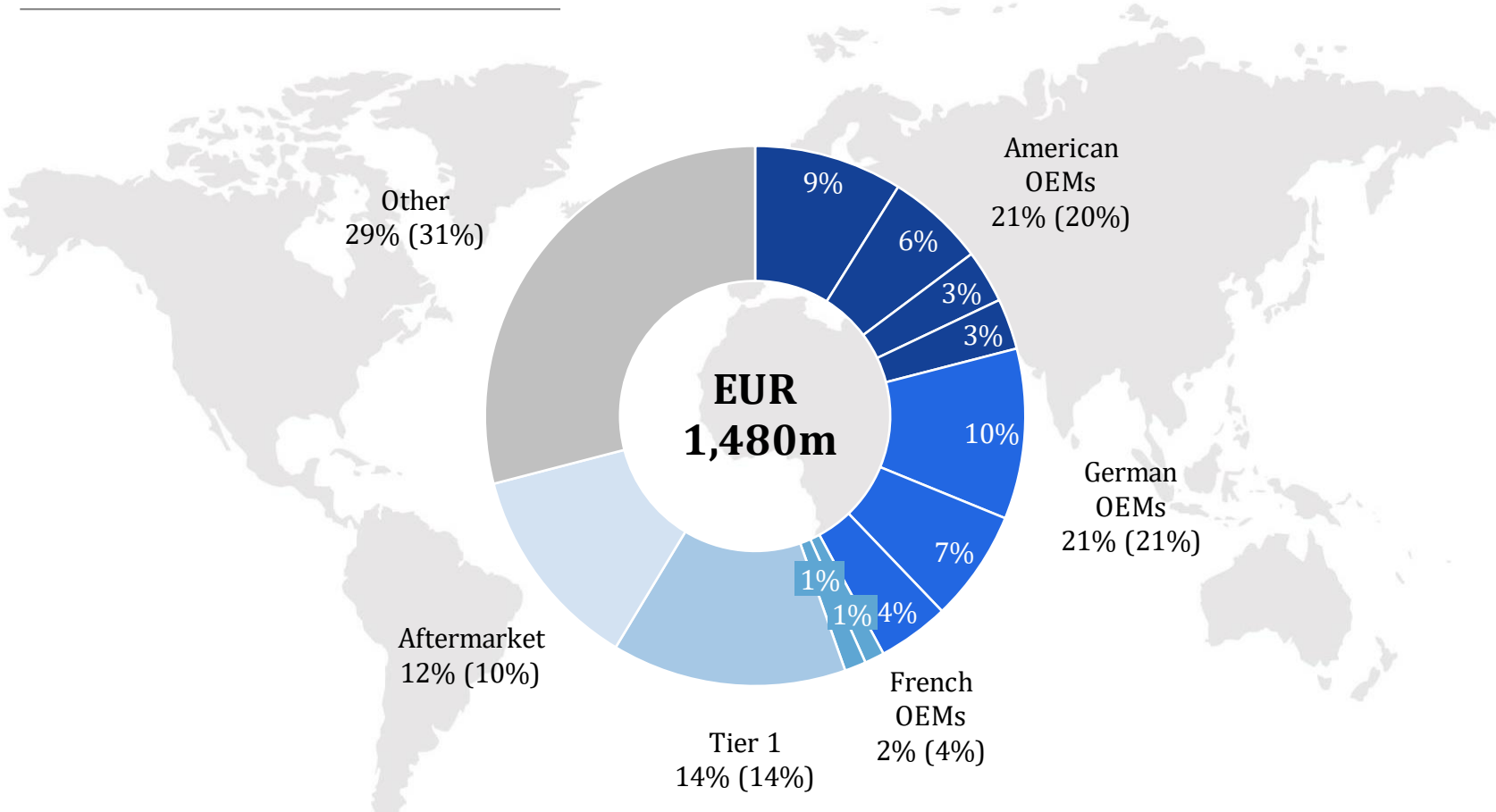



## Earnings

# Despite Covid-19 impact, EBITDA on prior year's level

EBITDA/margin – in EUR million/% of total sales

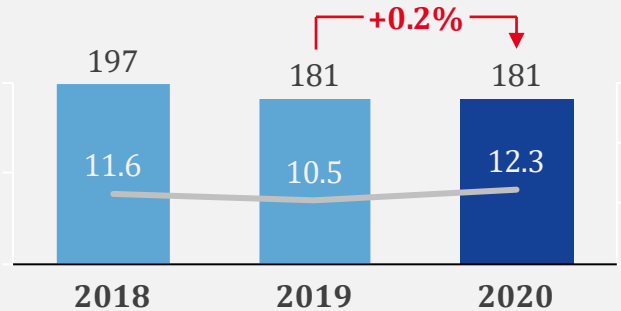

EBIT – in EUR million

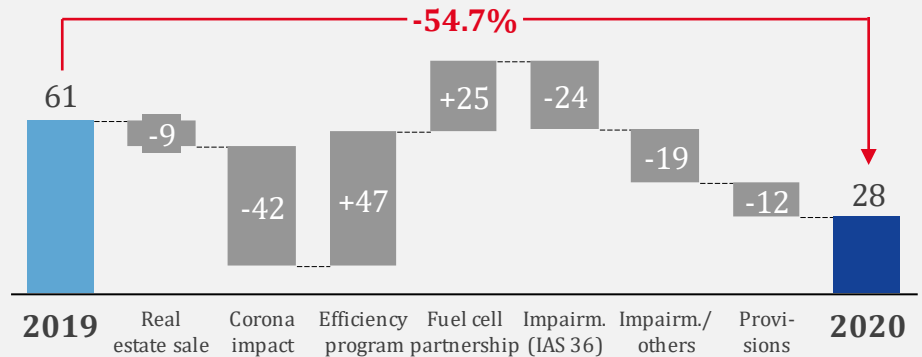

EBT – in EUR million

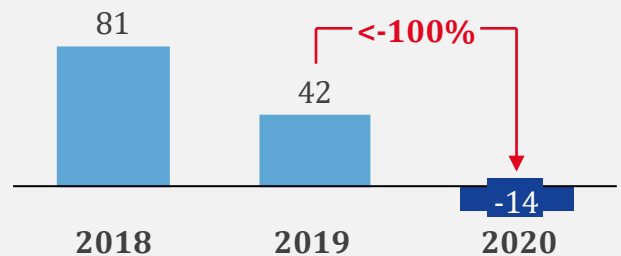

Earnings per share – in EUR



- Unrealized FX losses and losses from associates burdened net financial result
- Tax affected by deductibility of asset remeasurements and profit structure of Group entities

# Triple-digit operating free cash flow for the second time in a row

Capex/ratio – in EUR million/% of total sales

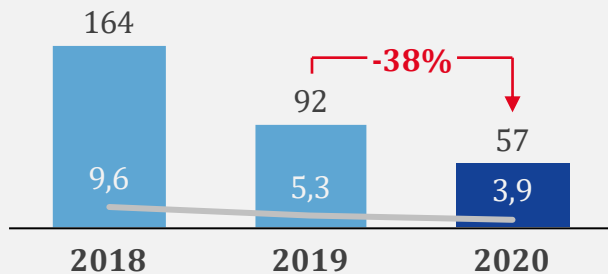

Net working capital/ratio – in EUR m/% of sales

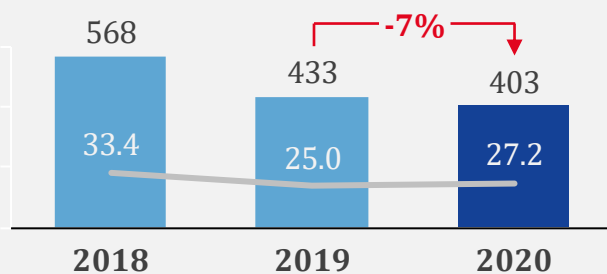

Operating free cash flow – in EUR million

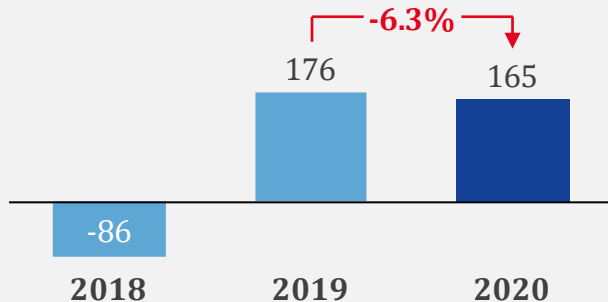

Equity/ratio – in EUR million/% of total assets

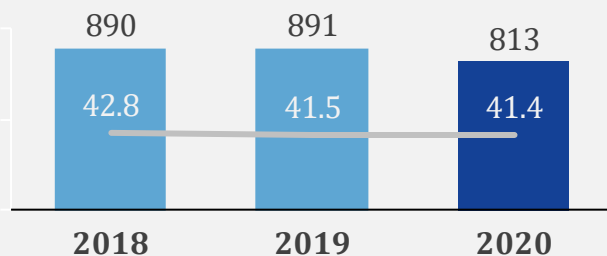

- Disciplined capex approach continued, net working capital despite pandemic further optimized
- Robust equity ratio again within the target corridor of 40 to 50 % of total assets

## Balance sheet

# Net debt reduced by more than EUR 330m within 21 months

Net debt/ Net debt/EBITDA – in EUR million

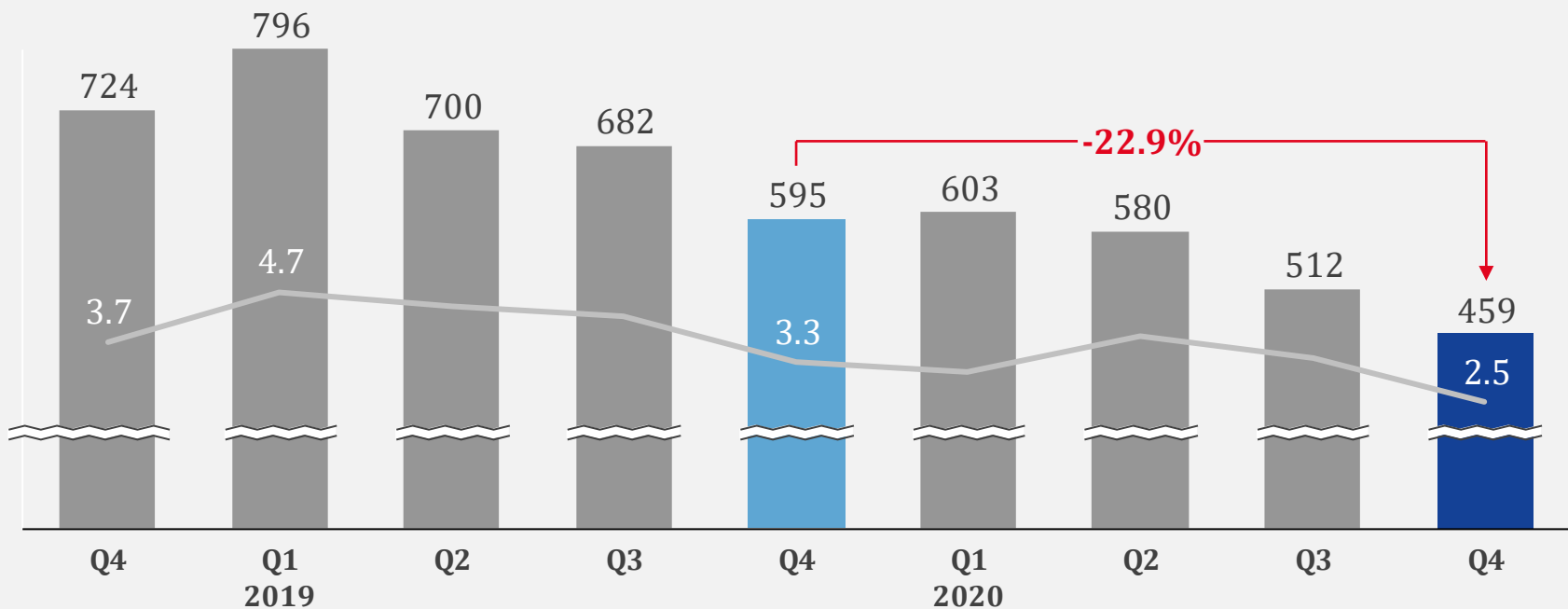

- Disciplined capex and optimized net working capital resulted in significant debt reduction
- Despite challenging covid-19-year, net debt/EBITDA ratio further decreased

## Segments

# Again strong Aftermarket performance

Sales – in EUR million

EBIT margin – in % of segmental sales

### Original Equipment (OE)

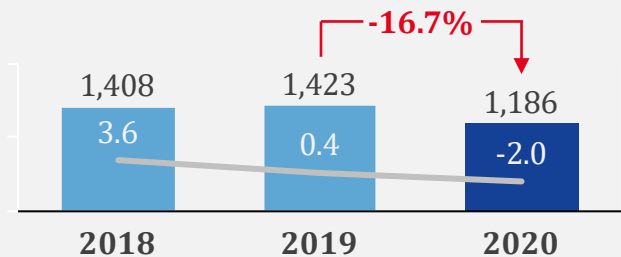

### Aftermarket

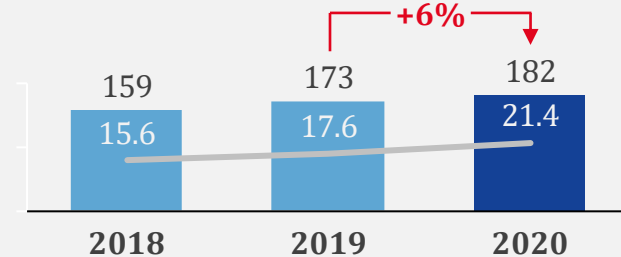

### Engineered Plastics

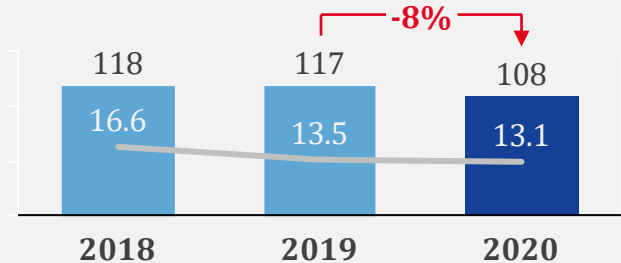

### Others

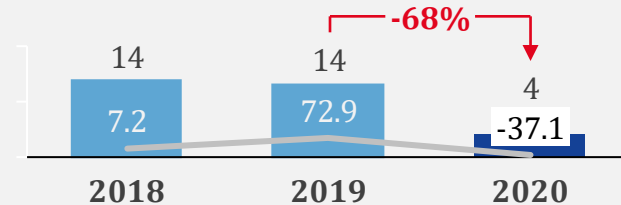

- Aftermarket with strong sales and earnings performance in Covid-19 year
- Engineered Plastics showing robust results while being affected by pandemic impacts

# Continuing improvement efforts into the next phase

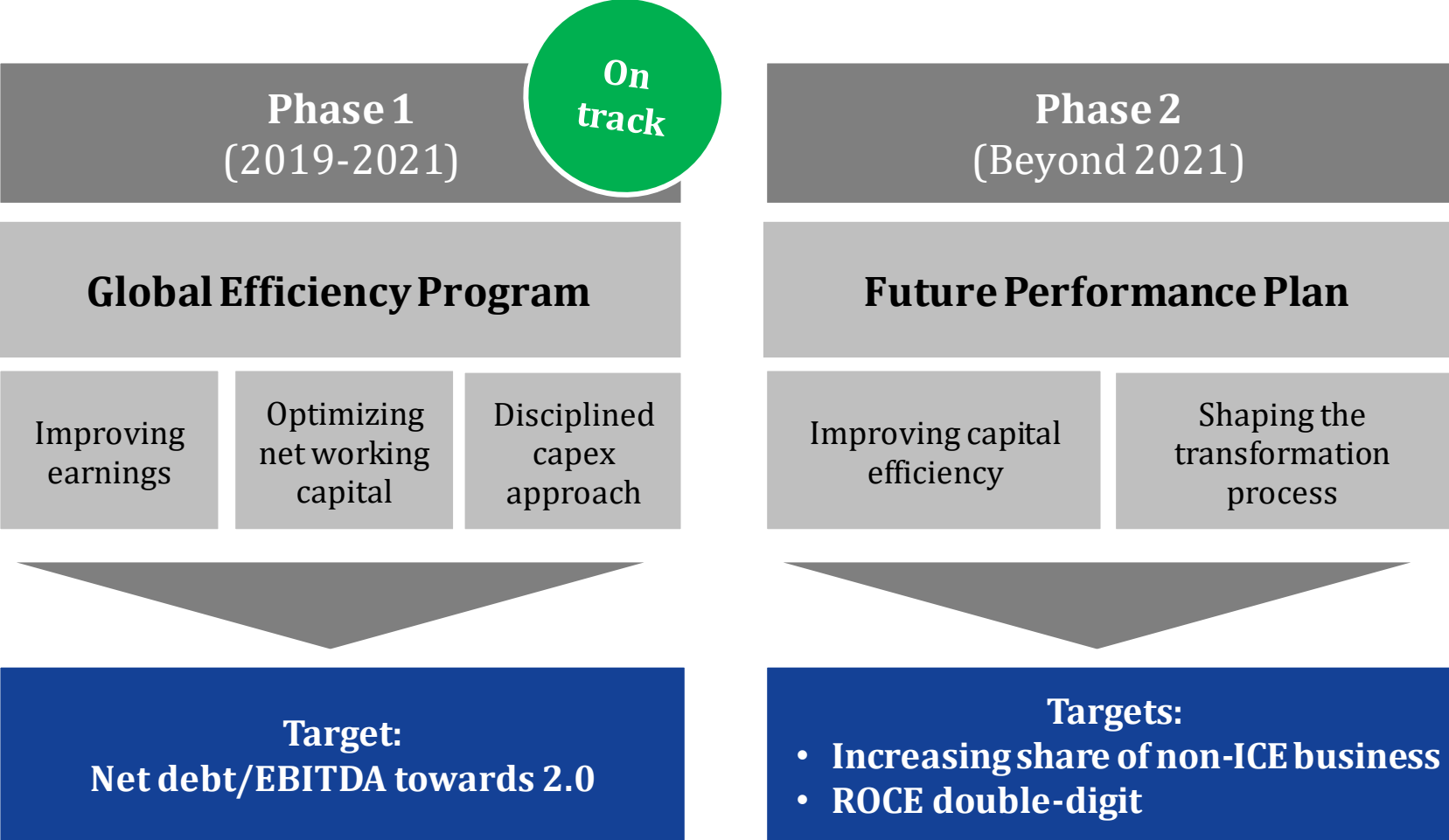

# Outlook

$H_2$



# Global LV production will reach pre-pandemic level in 2023

Light vehicle production by region – in million units

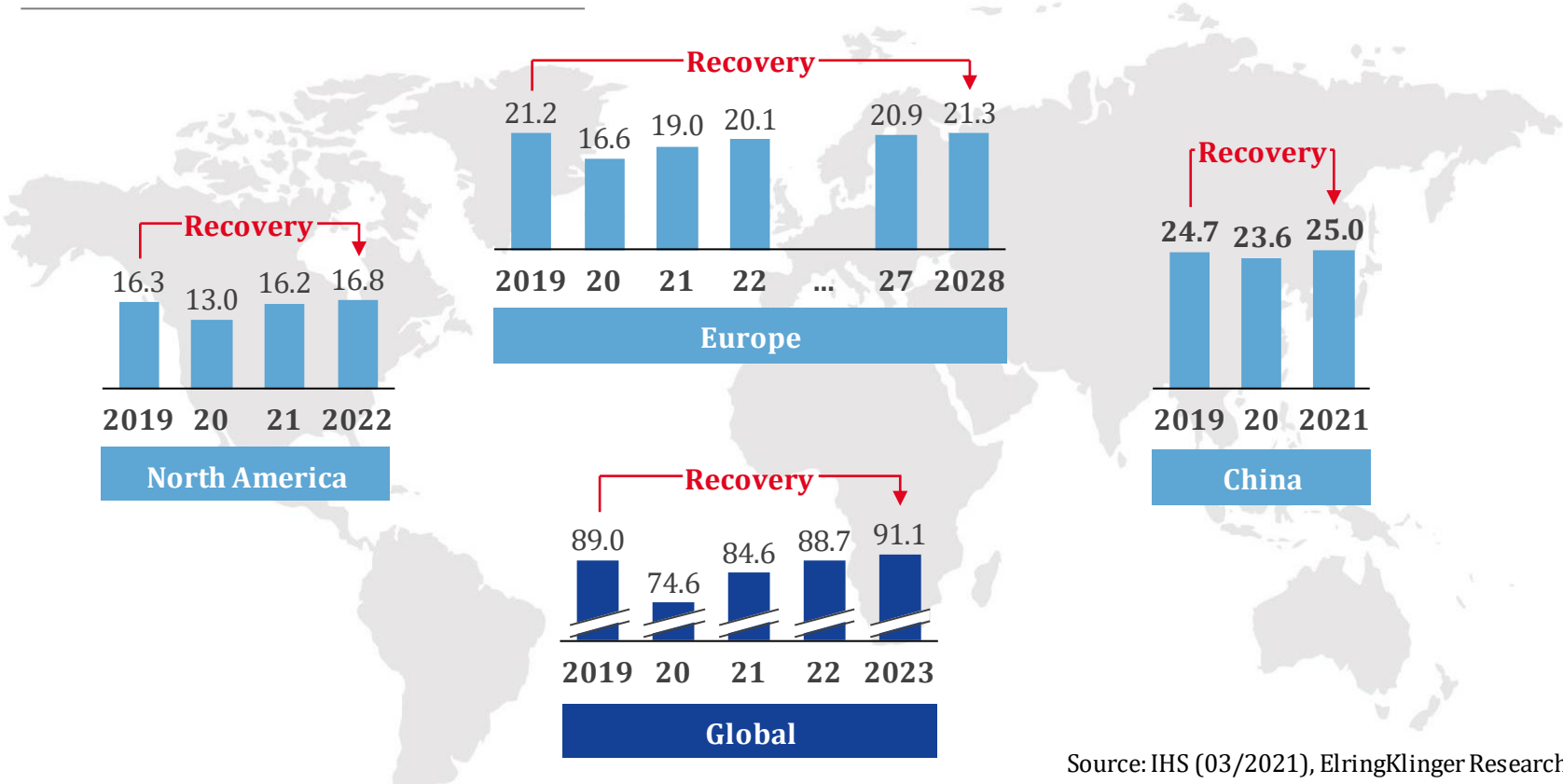

Source: IHS (03/2021), ElringKlinger Research

While China already on pre-pandemic level this year, North America will fully recover until 2022. Europe will need until 2028 to get back to 2019-level, which will be globally reached by 2023.

Market outlook

# FY2021 growth driven by recovery in North America and Europe

Light vehicle production by region – in million units

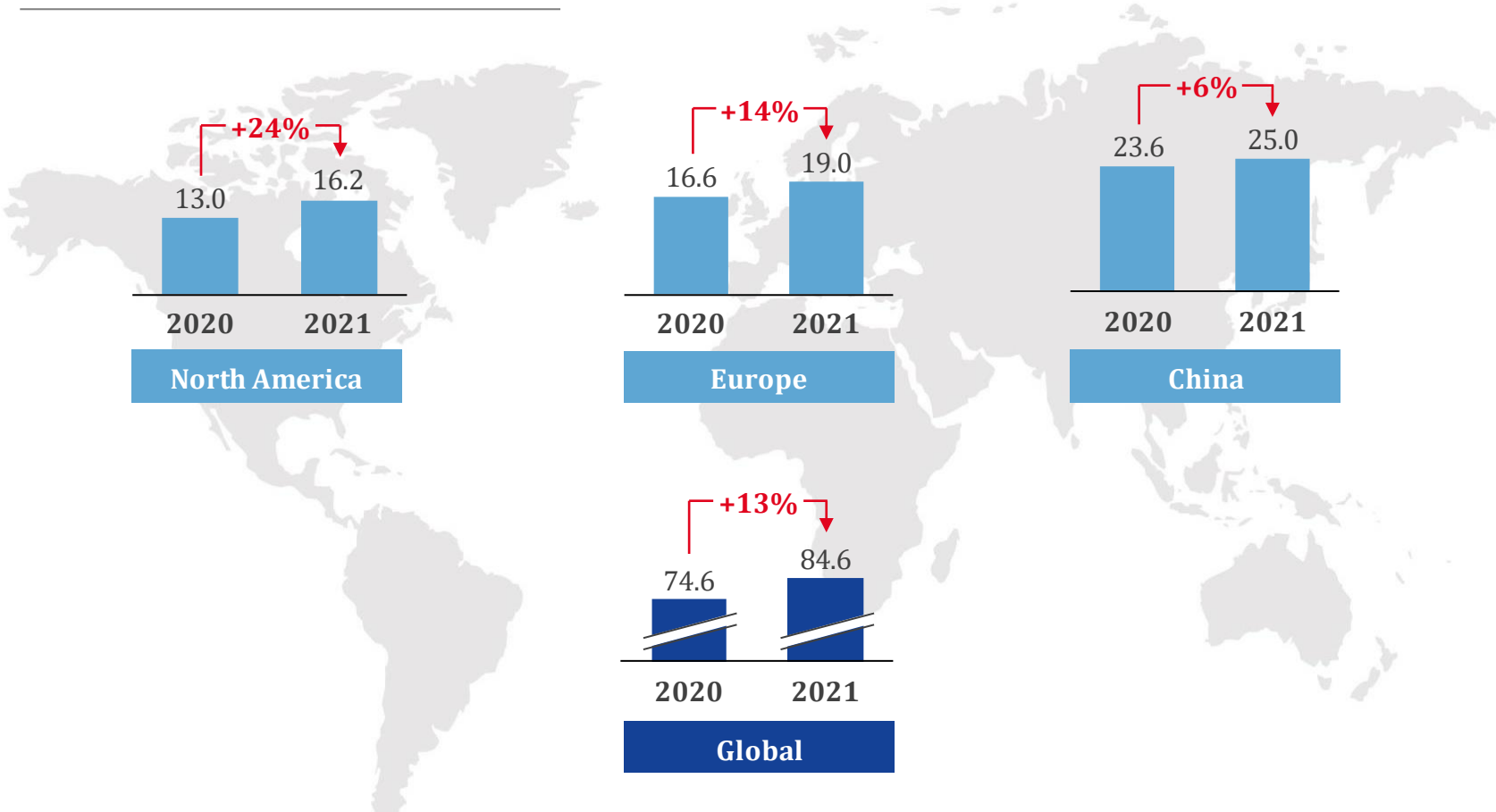

Source: IHS (03/2021), ElringKlinger Research



## Outlook for key indicators

# 2021

# Midterm

<b>Sales</b>	Organic growth approximately at level of global LV production	Organic growth outpacing global LV production growth
<b>EBIT margin</b>	Around 4 to 5%	Gradually improving
<b>ROCE</b>	Visible year-on-year improvement	Steady annual improvement
<b>Operating FCF</b>	Positive in double-digit million-euro range	Positive
<b>Net debt/ EBITDA</b>	Year-on-year improvement	Less than 2.0

# Appendix

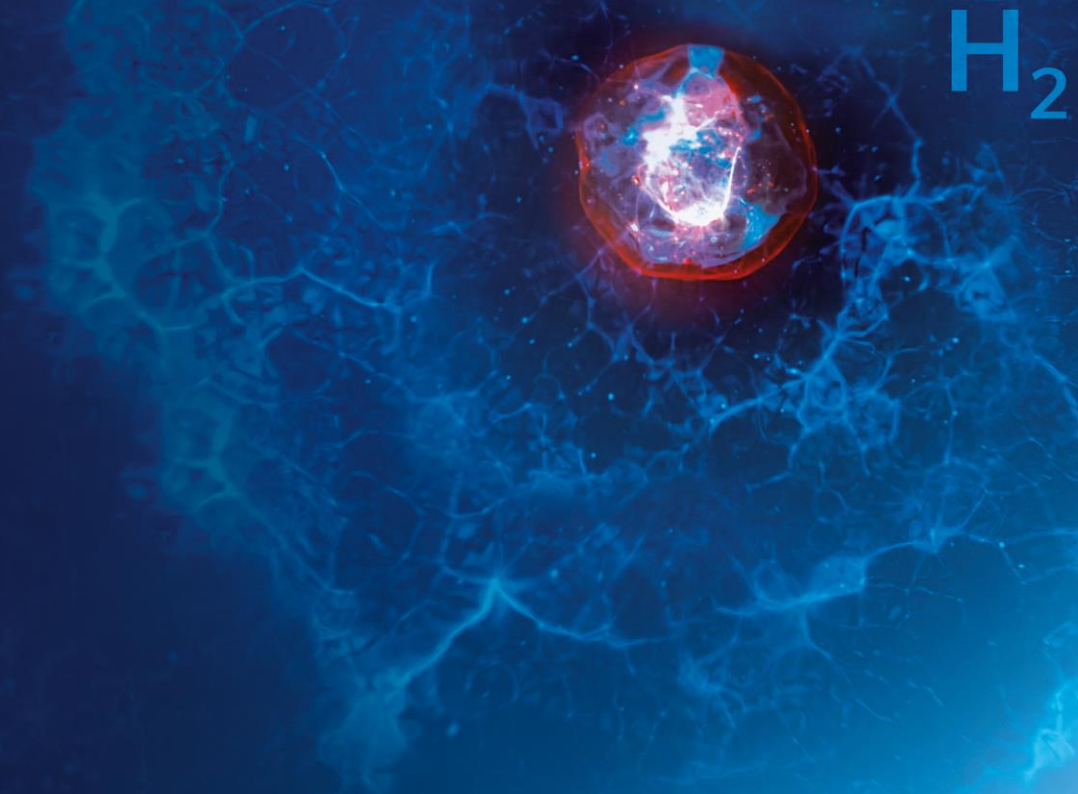

# Structural overview

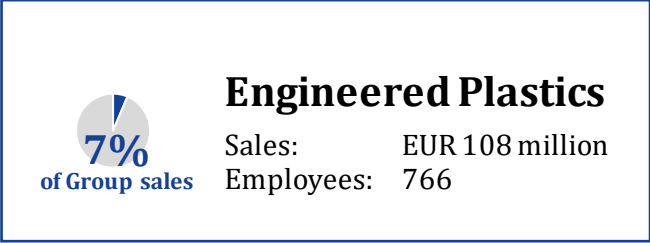
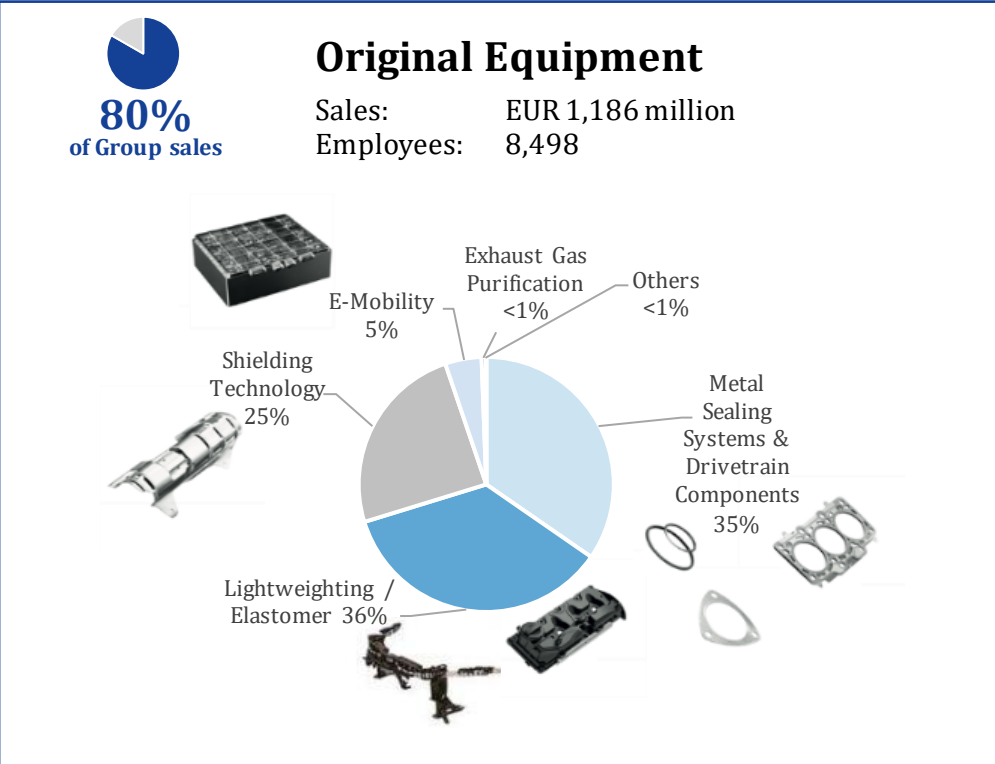

**Group sales**  
 EUR 1,480m

**EBIT**  
 EUR 27.7m

**EBIT margin**  
 1.9%

**Employees**  
 9,724

All figures refer to FY 2020

Group – FY 2020

## Consolidated income statement

	2020	2019
<b>Sales revenue</b>	<b>1,480</b>	<b>1,727</b>
Cost of sales	-1,196	-1,402
<b>Gross profit</b>	<b>285</b>	<b>325</b>
Gross margin	19.2	18.8
		in %
Selling expenses	-107	-133
General and administrative expenses	-73	-85
Research and development costs	-64	-64
Other operating income	10	34
Other operating expenses	-24	-15
<b>Operating result (EBIT)</b>	<b>28</b>	<b>61</b>
Finance income	29	23
Finance costs	-64	-43
Share of result of associates	-7	1
<b>Net finance costs</b>	<b>-41</b>	<b>-20</b>
<b>Earnings before taxes (EBT)</b>	<b>-14</b>	<b>42</b>
Income tax expenses	-26	-37
<b>Net income</b>	<b>-40</b>	<b>5</b>
of which: attributable to non-controlling interests	1	1
of which: attributable to shareholders of ElringKlinger AG	-41	4
<b>Basic and diluted earnings per share (EPS)</b>	<b>-0.64</b>	<b>0.06</b>
		in EUR

All figures in EUR million unless otherwise describe, differences due to rounding

Group – FY 2020

## Consolidated statement of financial position

Assets	As at Dec 31, 2020	As at Dec 31, 2019	Liabilities and equity	As at Dec 31, 2020	As at Dec 31, 2019
Intangible assets	201	208	Share capital	63	63
Property, plant, and equipment	940	1,044	Capital reserves	118	118
Investment property	0	3	Revenue reserves	684	725
Financial assets	15	4	Other reserves	-89	-52
Shares in associates	17	24	<b>Equity attr. to shareh. of ElringKlinger AG</b>	<b>777</b>	<b>854</b>
Non-current income tax assets	0	0	Non-controlling interest in equity	36	37
Other non-current assets	4	5	<b>Equity</b>	<b>813</b>	<b>891</b>
Deferred tax assets	24	15	Provisions for pensions	157	148
Contract performance costs	10	9	Non-current provisions	20	19
Non-current contract assets	1	2	Non-current financial liabilities	392	570
<b>Non-current assets</b>	<b>1,212</b>	<b>1,314</b>	Non-current contract liabilities	8	12
Inventories	301	356	Deferred tax liabilities	14	16
Current contract assets	10	11	Other non-current liabilities	7	8
Trade receivables	231	233	<b>Non-current liabilities</b>	<b>597</b>	<b>774</b>
Current income tax assets	5	8	Current provisions	27	18
Other current assets	71	89	Trade payables	129	157
Cash and cash equivalents	128	135	Current financial liabilities	205	160
<b>Current assets</b>	<b>746</b>	<b>832</b>	Current contract liabilities	31	20
Assets held for sale	5	0	Tax payable	33	17
<b>Total assets</b>	<b>1,963</b>	<b>2,147</b>	Other current liabilities	125	110
			<b>Current liabilities</b>	<b>551</b>	<b>482</b>
			Liabilities in connection with assets held for sale	2	0
			<b>Total liabilities and equity</b>	<b>1,963</b>	<b>2,147</b>

All figures in EUR million unless otherwise describe, differences due to rounding

Group – FY 2020

## Consolidated statement of cash flows

	2020	2019		2020	2019
Earnings before taxes (EBT)	-14	42	Proceeds from disposals of PPE, intangible assets and investment property	18	10
Depreciation/amortization (less write-ups) of non-current assets	154	120	Proceeds from disposals of financial assets	3	6
Net interest	16	19	Proceeds from the disposal of subsidiaries	0	22
Change in provisions	9	6	Payments for investments in intangible assets	-14	-19
Gains/losses on disposal of non-current assets	5	2	Payments for investments in PPE and investment property	-57	-92
Share of result of associates	7	-1	Payments for investments in financial assets	-11	-10
Change in inventories, trade receivables and other assets not resulting from financing and investing activities	54	83	<b>Net cash from investing activities</b>	<b>-61</b>	<b>-84</b>
Change in trade payables and other liabilities not resulting from financing and investing activities	3	67	Dividends paid to shareholders and to non-controlling interests	-2	-1
Income taxes paid	-18	-28	Proceeds from addition of long-term loans	105	167
Interest paid	-15	-17	Payments for the repayment of long-term loans	-288	-107
Interest received	1	1	Changes in current loans	29	-163
Other non-cash expenses and income	17	-17	<b>Net cash from financing activities</b>	<b>-156</b>	<b>-104</b>
<b>Net cash from operating activities</b>	<b>218</b>	<b>278</b>	Changes in cash	1	89
			Effects of currency exchange rates on cash	-9	1
			Cash at beginning of the period	136	45
			<b>Cash at end of period</b> (as per financial statement)	<b>128</b>	<b>135</b>

All figures in EUR million unless otherwise describe, differences due to rounding

## Group – Last 5 years

# Key figures

	2020	2019	2018	2017	2016
Order intake	1,483	1,737	1,735	1,732	1,694
Order backlog	1,033	1,030	1,020	1,001	933
Sales	1,480	1,727	1,699	1,664	1,557
EBITDA	181	181	197	238	231
EBIT (reported)	28	61	96	137	136
EBIT margin <i>in %</i>	1.9	3.5	5.7	8.3	8.7
EBT	-13	42	81	110	124
Net income attributable to shareholders	-41	4	44	70	79
Earnings per share <i>in EUR</i>	-0.64	0.06	0.69	1.10	1.24
Dividend per share <i>in EUR</i>	0.00	0.00	0.00	0.50	0.50
Capex	57	92	164	156	171
Operating free cash flow	165	176	-86	-67	-4
ROCE <i>in %</i>	1.7	3.4	5.5	8.2	8.7
Net working capital	403	423	567	553	525
Equity ratio <i>in %</i>	41.4	41.5	42.8	44.0	47.2
Net financial debt	459	595	724	655	539
Employees (as at Dec. 31)	9,724	10,393	10,429	9,611	8,591

All figures in EUR million unless otherwise describe, differences due to rounding

Group – Last 5 years

## Segmental figures

		2020	2019	2018	2017	2016
<b>Group</b>	<b>Sales</b>	1,480	1,727	1,699	1,664.0	1,557.4
	<b>EBIT (reported)</b>	27.7	61.2	96.2	137.3	135.6
	<b>EBIT margin</b> <i>in %</i>	1.9	3.5	5.7	8.3	8.7
<b>Original Equipment</b>	Sales	1,186	1,423	1,408	1,382	1,294
	EBIT (reported)	-23.7	5.1	50.7	86.3	88.9
	EBIT margin <i>in %</i>	-2.0	0.4	3.6	6.2	6.9
<b>Aftermarket</b>	Sales	182.5	172.6	159.5	156.7	147.3
	EBIT (reported)	39.0	30.4	24.9	31.8	30.5
	EBIT margin <i>in %</i>	21.4	17.6	15.6	20.3	20.7
<b>Engineered Plastics</b>	Sales	107.6	117.5	117.8	111.1	101.7
	EBIT (reported)	14.0	15.9	19.5	18.5	14.9
	EBIT margin <i>in %</i>	13.0	13.5	16.6	16.7	14.7
<b>Others</b>	Sales	4.3	13.5	14.0	13.8	14.2
	EBIT (reported)	-1.6	9.9*	1.0	0.7	1.3
	EBIT margin <i>in %</i>	-37.2	73.3*	7.1	5.1	9.2

All figures in EUR million unless otherwise describe, differences due to rounding

\*incl. EUR 8.6m from the sale of the industrial park in Hungary



Group – Last 5 quarters

## Key figures

	Q4 2020	Q3 2020	Q2 2020	Q1 2020	Q4 2019
Order intake	512	424	193	355	382
Order backlog	1,033	972	929	989	1,030
Sales	451	381	252	396	420
EBITDA	88	49	-0.9	46	57
EBIT (reported)	25.2	18.9	-32.4	16.0	24.3
EBIT margin (in %)	5.6	5.0	-12.8	4.0	5.8
EBT	9.8	9.2	-38.7	6.2	19.5
Net income attributable to shareholders	-10.7	3.4	-35.5	2.0	7.5
Earnings per share (in EUR)	-0.17	0.05	-0.56	0.03	0.12
Capex (in PPE)	19.4	15.1	10.4	12.3	17.4
Operating free cash flow	62.4	78.6	25.8	-2.2	65.7
Net working capital <sup>1</sup>	403	407	417	453	423
Equity ratio (in %)	41.4	41.0	40.5	41.7	41.5
Net financial debt <sup>2</sup>	459	512	580	603	595
Employees (as at quarter-end)	9,724	9,770	9,991	10,373	10,393

<sup>1</sup> Incl. current contract assets, less current contract liabilities

<sup>2</sup> As from FY2020 reduced by time deposits and current securities

All figures in EUR million unless otherwise described, differences due to rounding

Group – Last 5 quarters

## Segmental figures

		Q4 2020	Q3 2020	Q2 2020	Q1 2020	Q4 2019
<b>Group</b>	Sales	451	381	252	396	420
	EBIT (reported)	25.2	18.9	-32.4	16.0	24.2
	EBIT margin (in %)	5.6	5.0	-12.8	4.0	5.8
<b>Original Equipment</b>	Sales	378	306	188	313	349
	EBIT (reported)	12.8	4.3	-40.5	-0.3	2.0
	EBIT margin (in %)	3.4	1.4	-21.4	-0.1	0.6
<b>Aftermarket</b>	Sales	44	47	39	52	42
	EBIT (reported)	8.9	9.6	7.7	12.8	7.9
	EBIT margin (in %)	20.4	20.3	19.7	24.5	18.9
<b>Engineered Plastics</b>	Sales	28.1	26.8	23.8	28.9	26.4
	EBIT (reported)	4.7	4.5	1.3	3.5	5.2
	EBIT margin (in %)	16.9	16.8	5.5	12.1	19.7
<b>Others</b>	Sales	0.8	0.7	1.0	1.8	3.3
	EBIT (reported)	-1.3	0.5	-0.8	-0.0	9.3*
	EBIT margin (in %)	n.a.	20.0	n.a.	-0.0	>+100*

All figures in EUR million unless otherwise described, differences due to rounding

\* incl. EUR 8.6m from the sale of the industrial park in Hungary

Group

# Product portfolio

Metal Sealing Systems & Drivetrain Components

E-Mobility

- Battery module
- PEM fuel cell
- Electric drive unit (EDU)

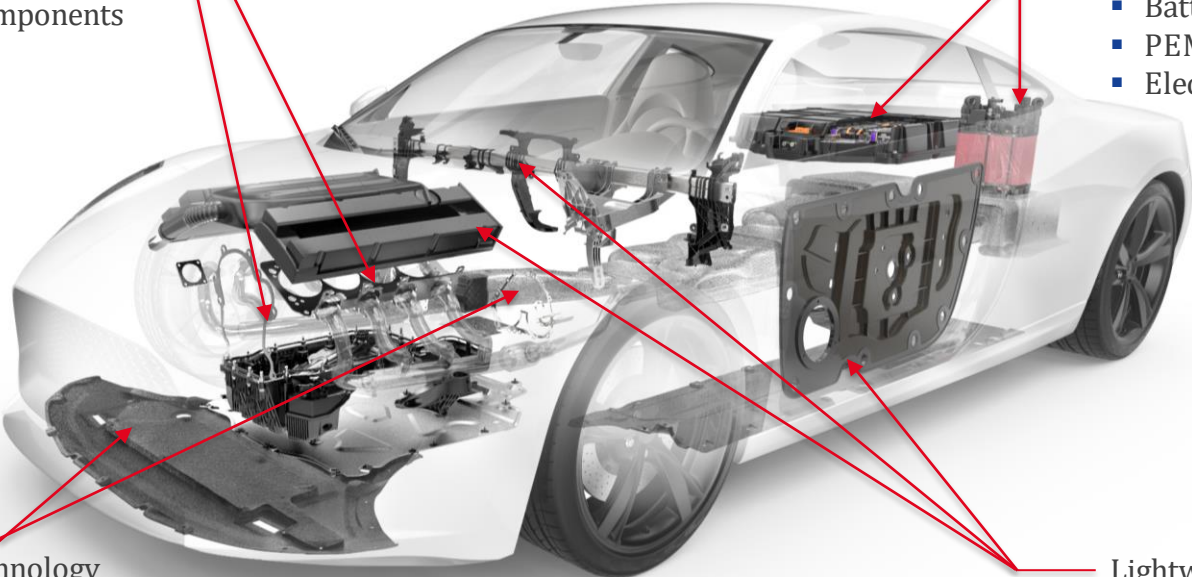

Shielding Technology

- Thermal shielding
- Acoustic shielding

Lightweighting/  
Elastomer Technology

- Door module carrier
- Cockpit cross-car beam
- Plastic modules (cam cover)

Group

# ElringKlinger represented in all important auto regions

Production locations of global top 15 OEMs (●)  
ElringKlinger production sites (◆)

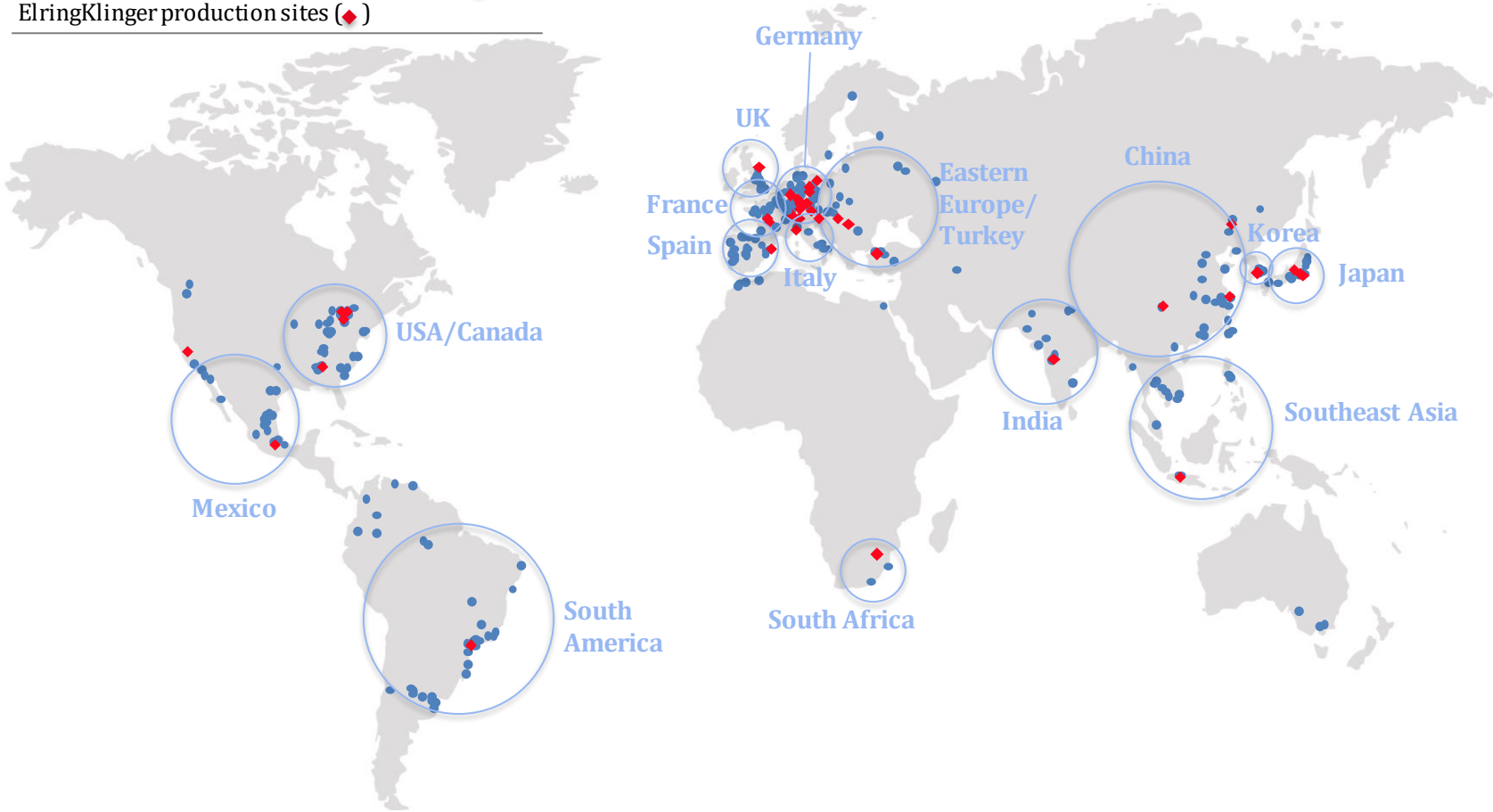

Group

## Focused R&D activities

R&D – in EUR million

R&D ratio – in % of total sales

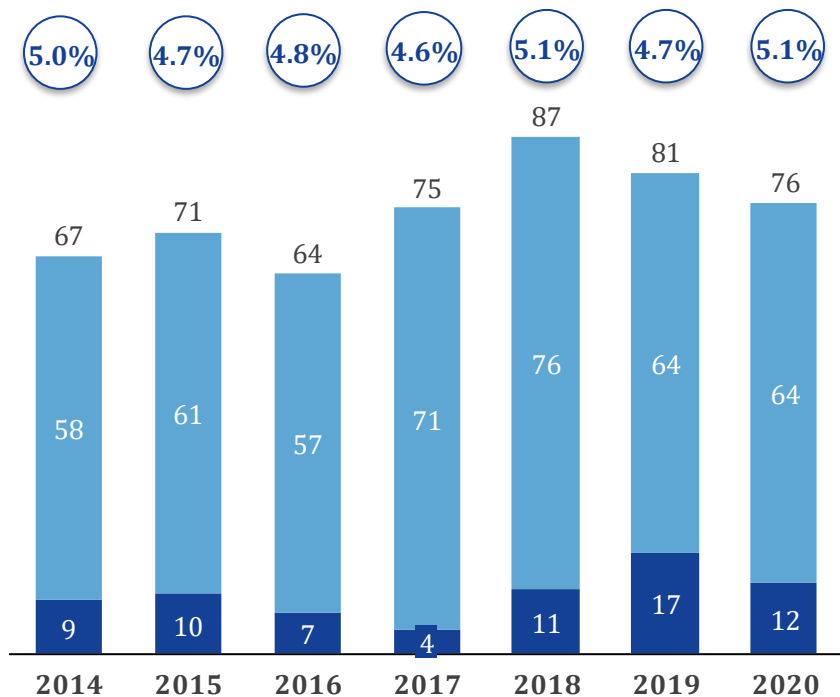

- **Integration of tools implies a technological lead position** in the development of ideas
- **Main focus:** lightweight components, e-mobility
- 623 R&D employees
- 86 new international patents in 2020
- **Target R&D ratio** (incl. capitalization): 5 – 6% of total sales, capitalization rate ~20%

■ thereof capitalized

# Group

## Senior management



**Dr. Stefan Wolf, CEO**  
(since 2005)

---

**Corporate units**

Legal & Compliance  
HR  
Strategic Communications  
Marketing & Communications  
Global Strategy, M&A and Innovations  
OE Sales

**Business units**

Aftermarket

**Group entities**



**Thomas Jessulat, CFO**  
(since 2016)

---

**Corporate units**

Finance  
Information Technology  
Supply Chain Management



**Theo Becker, CTO**  
(since 2006)

---

**Corporate units**

Purchasing  
Tooling Technology  
Product Risk Management  
Real Estate & Facility Mgmt.

**Business units**

Battery Technology & E-Mobility  
Drivetrain Technology



**Reiner Drews, COO**  
(since 2018)

---

**Corporate units**

Production  
Quality & Environmental Management

**Business units**

Metal Sealing Systems & Drivetrain  
Components  
Lightweighting/Elastomer Technology  
Shielding Technology

**Domestic plants**  
in the OE segment

## Group

# More than 140 years of experience and solid shareholder structure

### History of ElringKlinger in very brief

- 1879** Paul Lechler establishes a merchandising business in Stuttgart for technical products and gaskets.
- 1885** Richard Klinger establishes an engineering office in Vienna.
- 1924** The first Lechler cylinder-head gaskets are produced.
- 1964** Elring production and development moves from Stuttgart to Dettingen/Erms.
- 1993** Elring goes to Asia: The joint venture Changchun Elring Gaskets Co. Ltd. has been founded.
- 1994** Elring GmbH merges with Automotive Division of Richard Klinger GmbH to ElringKlinger GmbH.
- 1997** ElringKlinger founds new plants in UK, Brazil, Mexico, and the U.S.
- 2000** ElringKlinger GmbH merges with parent company ZWL Grundbesitz- und Beteiligungs-AG and is renamed as ElringKlinger AG.
- 2001** ElringKlinger intensifies R&D work on fuel cell components, especially on its internal sealing.
- 2002** Registered shares of ElringKlinger AG are traded at Frankfurt and at Stuttgart Stock Exchange.
- 2010** ElringKlinger receives its first order for series production of cell contact systems used in lithium-ion batteries.
- 2013** ElringKlinger acquires tool maker Hummel Formen GmbH which enables the company to offer structural lightweight components.
- 2017** ElringKlinger extends its portfolio to alternative drive technologies by acquiring a stake in hofer
- 2018** ElringKlinger sells interest in Hug and in new enerdag
- 2020** ElringKlinger enters into new strategic partnerships with Airbus and Plastic Omnium in fuel cell business

### Shareholder structure as at December 31, 2020

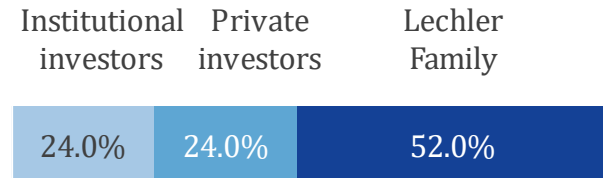

**ElringKlinger AG**  
**Strategic Communications**  
**Max-Eyth-Str. 2**  
**72581 Dettingen/Erms | Germany**  
**Mail: [info@ir.elringklinger.com](mailto:info@ir.elringklinger.com)**

# Disclaimer

## Forward-looking statements and predictions

This presentation contains statements about the future. These statements are based on current expectations, market evaluations and predictions by the Management Board, and on information that is currently available to them. The statements about the future should not be interpreted as guarantees of the future developments and results that they refer to. Whilst the Management Board is convinced that the statements that have been made, and the convictions and expectations on which they are based, are realistic, they rely on suppositions that may conceivably prove to be incorrect; future results and developments are dependent on a multitude of factors, they involve various risks and imponderabilities that can affect whether the ongoing development deviates from the expectations that have been expressed. These factors include, for example, changes to the general economic and business situation, variations of exchange rates and interest rates, poor acceptance of new products and services, and changes to business strategy.